

Front of House / Luggage trolleys

# Vesuvio 1100

Chariot de groupe, un grand classique



## Équipement standard

- Penderie intégrée
- Moquette sur base (divers coloris)
- Pare-chocs périphérique souple non marquant
- 2 roues fixes et 2 roues pivotantes Ø 200 mm, ultrasilencieuses, caoutchouc non marquant

# Options

- Personnalisation des couronnes avec le logo de votre établissement
- Frein centralisé
- Roues pivotantes à frein
- Roues pneumatiques Ø 230mm
- Housse de protection (personnalisable)
- Motorisation

## VESUVIO 1100

# Coloris

### Anodisation finishes



**Silver anodised**



**Gold look**

### Carpet finishes



**Blue**

Ref xx = 40

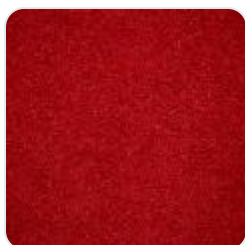

**Red**

Ref xx = 41



**Black**

Ref xx = 42



**Brown**

Ref xx = 43

# Dimensions

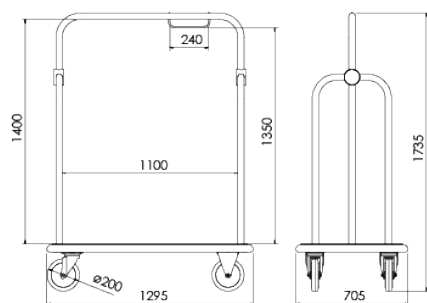

## VESUVIO 1100

### Overall dimensions

Width	Depth	Height	Wheels Ø
1295 mm	705 mm	1735 mm	200 mm

### Inside dimensions

Width	Height
1100 mm	1350 mm