

Front of House / Luggage trolleys

e-Vesuvio 1100

Chariot de groupe, un grand classique



Équipement standard

- Largeur utile de 1 100 mm
- Penderie intégrée
- Moquette sur base (divers coloris)
- Pare-chocs périphérique souple non marquant
- 2 roues fixes et 2 roues pivotantes Ø 200 mm, ultrasilencieuses, caoutchouc non marquant

Technical info

- Poids à vide : 89 kg
- Capacité de charge : 250 kg
- Autonomie de travail : au moins 1 jour de travail
- Temps de recharge : 7 heures
- Puissance : 350 W
- Batterie : AGM 12 V
- Vitesse maximum en marche avant : 6 km/h
- Vitesse maximum en marche arrière : 3 km/h
- Certification CE

E-VESUVIO 1100

Options

- Roues pneumatiques
- Frein centralisé
- Personnalisation des couronnes avec votre logo
- Crochet à gauche et/ou à droite
- Pédale de relevage de la roue motrice

E-VESUVIO 1100

Coloris

Anodisation



Silver



Gold mat



Black mat

Carpet



Blue



Red



Black



Brown

Woven vinyl



Graphite



Sand



Stone

Dimensions

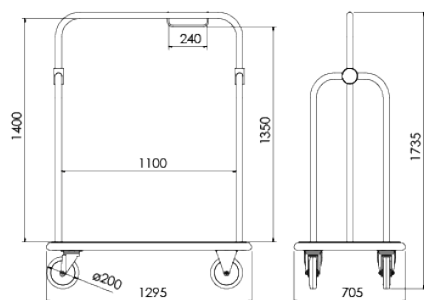

E-VESUVIO 1100

Overall dimensions

Width	Depth	Height	Wheels Ø
1295 mm	705 mm	1735 mm	200 mm

Inside dimensions

Width	Height
1100 mm	1350 mm